

Device Installation:

Special Note:

Device should be installed with barcode facing the ground and should be placed directly under a thick panel to maximize performance while being protected from external elements.

1. **Make** sure your vehicle is outdoors.
2. **Locate** the vehicles device connection port, this is usually located under the dash close to the front windshield. **(Fig.1)**
3. Continue with plugging the MiFleet device into port. Typical connection sequence:
 - Connect any peripherals to the device.
 - Plug in power harness, complete. **(Fig. 2)**
4. Ensure the vehicle ignition is on.
5. Communication verification is critical for proper functionality of device. First verify that the device has been acquired and has registered to the wireless network. This may be verified in one of two ways.
 1. Check status LED lights for red light, if solid, data connection is good.
 2. If no connection please contact MiFleet support at 866.643.5338 opt 2.



| LED | Indication | Description |
|--------------------|--|--|
| PWR (Green) | <ul style="list-style-type: none"> • Solid On • 1 blink (.1sec) in every 8 secs | <ul style="list-style-type: none"> • In full operation mode • In sleep mode |
| GPS (Red) | <ul style="list-style-type: none"> • .7 secs On / .7 secs off • Solid on | <ul style="list-style-type: none"> • Searching for GPS signal • Postion fixed |
| WWAN (Red) | <ul style="list-style-type: none"> • Off • 7 secs On / .7 secs off • .2 secs on / 2 secs off • 2 blinks in every 2 secs • Continuous blinking | <ul style="list-style-type: none"> • WWAN module off • Searching for WWAN signal • Registered to WWAN network • Connected to WWAN network • SIM PIN Error |
| WiFi Hotspot (Red) | | |
| Bluetooth | <ul style="list-style-type: none"> • Solid On • Off | <ul style="list-style-type: none"> • If a BT gadget is connected • No BT gadget is connected |



Commerical Fleet AK11

What's Included:

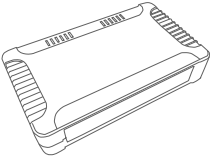

AK11 Device

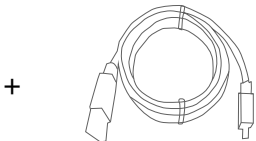

Proper Vehicle Cable

Device Installation:

Special Note:

Depending on the type of vehicle you have and cable setup you require will depend on how to install this device.

Light Duty & Heavy Duty Port:

1. Locate the vehicles OBD diagnostic port, this is usually located on the driver's side of the vehicle under the dash, hidden behind a cover plate, or on the side of a center console.

**Some foreign/ luxury vehicles such as Toyota, Honda, BMW, etc .. may have a slightly different variation of the standard OBDII plug and/or have the plug hidden in a nonstandard location. If you have a foreign vehicle, and cannot locate your OBD port, please consult your user manual or local dealership to help locate it.*

**In Heavy Duty vehicles the port should be in the door jam.*

2. Once the diagnostic port has been located, plug the MiFleet hardware into the port.

Light Duty Connection Diagram:

Fig. 1



Fig. 2



Heavy Duty Connection Diagram:

Fig. 3



Fig. 4



Hardwire Installation:

1. **Locate** your vehicle's unswitched 12V/24V power line, ignition sense (greater than 8.5V) and ground line. Verify that the ignition sense exceeds 8 volts when on.

**For best results, it is strongly recommended that the Device connection be on its own circuit. If possible, connect the power input directly to the vehicle battery and protect the circuit with an inline fuse. If you must connect through the fuse box, use standard commercial wiring practices to create a permanent installation rather than using press-in fuse clips or other temporary measures.*

2. **Connect** black wire to vehicle's ground line.
**Must be connected to chassis ground.*

3. **Connect** red wire to vehicle's primary power source.
**Must be connected to a constant (unswitched) +12 VDC or +24 VDC supply. The preferred method is to connect directly to the vehicle battery terminal line.*

4. **Connect** yellow wire to vehicle's ignition line.
**The ignition line must be connected to the vehicle ignition or another appropriate key operated line, such as ACCESSORY, ensuring that power to the ignition wire is available only when the vehicle ignition is on.*

Wire Connection Diagram:

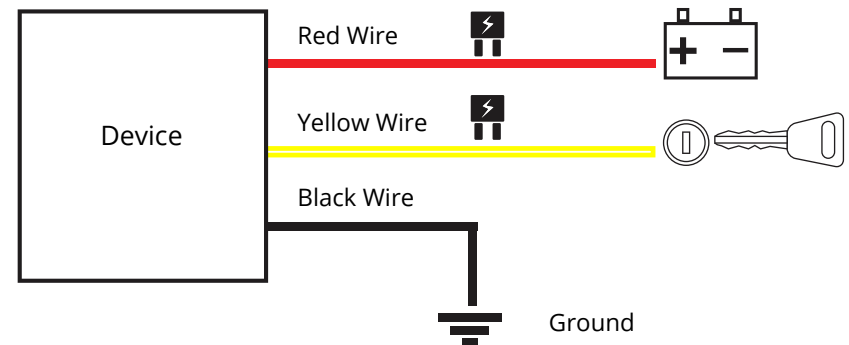

Failure to connect these lines as described may result in discharge of the vehicle battery.

Continued on back